



SHEET PLATE FILM EQUIPMENT



Sheet
Extrusion Line



Plate&Film
Extrusion Line

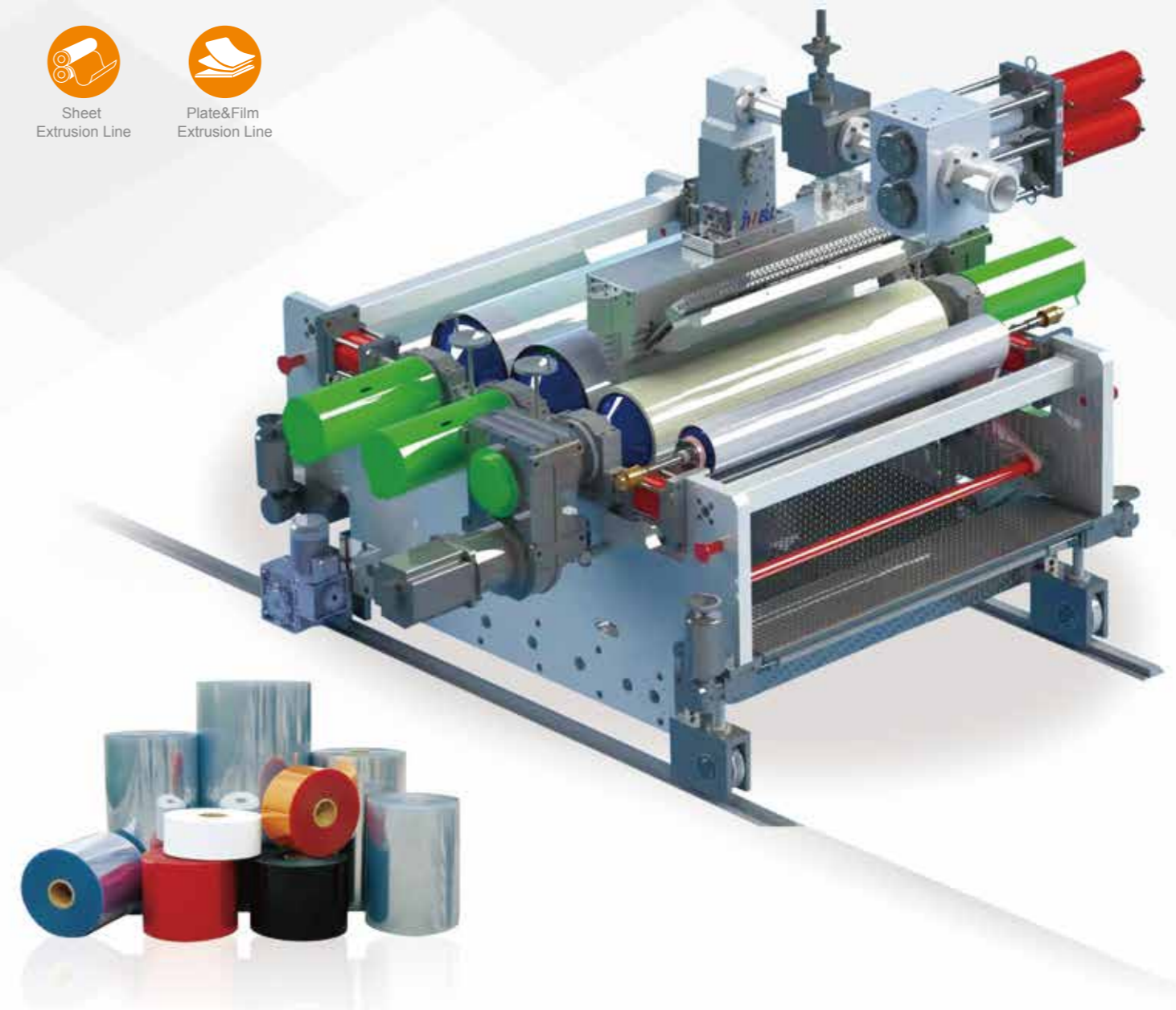

地址：江苏省常州市溧阳中关村开发区上上路118号
电话：0519-87108958 13916215585
Add: No.118,shangshang Road,Licheng Town,Liyang,Changzhou city,China
Tel: +86-519-87108958 13916215585
Http://www.jwell-znzb.com www.jwell.cn

邮编(p.c): 213300
传真 (Fax): 0519-87108958
Fax:86-519-87108958
E-mail: sales@jwell.cn
Complaint E-mail:info@jwell.cn

版本号Edition No.: 2022.03

常州金纬智能装备制造有限公司
Changzhou Jwell Intelligent Equipment Co., Ltd.

常州金纬简介

常州金纬是上海公司的又一重要发展战略中心，其坐落于江苏省溧阳市江苏中关村科技产业园内，是一家致力于塑料挤出成型设备的研发、制造的高科技厂家。厂区占地面积400余亩，公司拥有一支高素质的研发队伍和经验丰富的机械、电气调试工程师团队，以及先进的机械加工基地和规范的装配车间。公司本着“用心持久、拼搏创新”的企业精神，不断探求挤出新领域的开拓。热烈欢迎国内外新老客户莅临我公司参观、指导、合作、我们愿为您提供强有力的支持。



公司产品遍布全球各地，包括俄罗斯、印度、韩国、印尼、中东、非洲和南美洲、西班牙、意大利等100多个国家和地区，深受用户好评。

“品质卓越 完美如一”

是金纬公司的质量方针，是全体员工努力的方向。

“诚实待人”

是我们铸就“百年金纬”的核心理念。

董事长：何海潮

Email: he@jwell.cn

CHANGZHOU JWELL MACHINERY

JWELL CHANGZHOU is another development strategy center of Shanghai JWELL Machinery Co.,Ltd, locating at Jiangsu province,a high-tech manufacturer specializing in research and development of plastic extrusion equipment. The factory area is of 400 acres;We have a high qualified R&D and experienced mechanical and electrical engineer team as well as advanced processing foundation and normative assembly shoop. Our enterprise spirit is"Attentive,Enduring,Quick and Orderly",keeping on exploring of new extrusion field.Mostly welcome to new and old customers to visit us for investigation, guidance and cooperation. We are happy to offer powerful support!

Company products all over the world, as well as Russia, India, South Korea, Indonesia, the Middle East, North and Latin Americas, Spain, Italy etc., more than 100 countries and regions, praised by users.

"Excellent Quality, Perfect All" is Jwell's quality policy, and all staff's working direction.

"Be honest" is the core idea for us to contribute
"Century JWELL"

President:He Haichao

Mobile /WhatsApp +86 13601628188



IXPE发泡卷材生产线

IXPE Foaming Coil Extrusion Line



IXPE交联聚乙烯发泡卷材线包含以下四步生产流程：

造粒-----挤出母片-----发泡成型-----辅机收卷

一、常见的三种造粒方式：

- 密炼--开炼--拉片--冷却--切粒；
- 密炼--单螺杆挤出--水环（风冷）切粒；
- 高速搅拌机--平双挤出机--单螺杆挤出机--水环（风冷）切粒。

二、挤出母片：金纬公司根据多年IXPE螺杆设计制造经验，不断地改进IXPE螺杆的结构设计，改进机筒以及螺杆的温控和冷却系统，对模具的内部结构优化设计，采用立式镜面三辊压机成型，配备高精度的恒温系统，使得IXPE母片材挤出过程中稳定连续，确保物料塑化分散均匀，温度易于控制。

三、发泡成型：

- A、水平炉：**发泡炉采用新型三段加长炉，炉体分为预热段、交联段、发泡段三部分，炉体全长 23 米，高 5.5 米，宽 3.5 米。配置名牌高精度节能燃烧器，确保温度得到精确控制，可生产XPE、IXPE，橡塑发泡产品。
- 特点：**能耗低：将预热段、交联段做了较大改变，满足工艺要求的情况下，减少热容空间，节能降耗，燃气用量与两段炉相当；
- 生产工艺范围宽：**炉内热量分布上，克服炉体内热量分布不合理的缺陷，按照IXPE 发泡的工作热量要求，使得IXPE发泡在一个比较宽的范围内，发泡倍率在5-35倍，发泡充分，连续稳定；
- 产量大：**在目前国内生产的发泡炉中，我们的三段炉产量大，可达 200KG/H 以上，而且IXPE泡孔比两段炉更细密。
- B、垂直炉：**该线包含放卷装置、送料牵引装置、网带张紧装置、网带驱动装置、预热炉体、垂直炉体、扩幅装置等。

特点：加热均匀、热量损失小、产能大、能耗低，操作简单。

经过辐照后的制品广泛应用于：电子领域、汽车领域、建筑领域、医疗、缓冲包装、运动休闲等诸多领域。其中地板静音垫、平衡层经电子辐照后，环保无毒，耐老化、腐蚀；独立闭孔结构，有效防止潮气侵蚀地板；优秀的隔音性能，能减少楼层间的噪音传播；使用过程中提升脚感舒适度。

四、辅机收卷：辅机全长20米，依次通过五辊定型机、风冷系统、表面整形、自动纠偏切边装置、牵引机、双工位收卷机。

以上挤出母片、发泡成型、收卷辅机三部分全长60米左右。

五、电子辐照收放卷系统：IXPE电子交联发泡卷材在发泡前需要经过电子辐照，该设备为卷材进入电子加速器室前的整套辅机设备，包含放卷装置、牵引机、放卷储料、纠偏装置、收卷储料、收卷机等。

特点：配合电子加速器电子辐照量设定收放卷速度，自动化程度高；整机多点张力控制单元保证片材张力稳定。配备品牌过程纠偏系统，有效保证片材齐整。

IXPE crosslinked foamed PE roll material line contains the following four – step process:

PELLETIZING----EXTRUDE----- FOAMING -----WINDER

1、Normal pelletizing method:

Banburying ---open mill --zipper pulls---cooling --cutting.
Banburying---single screw extruder --water circulation (or air cooling)cutting.
High speed blender--parallel twins screw extruder---single screw extruder--water circulation (or air cooling)cutting.

2、Extrude:

Jwell screw design and manufacture based on IXPE experience, Continuously improve the structure of IXPE screw design, improved barrel and screw temperature control and cooling systems, On inner Structural Optimization Design of mould, Formed with vertical mirror of three - roll calender, equipped with high precision temperature control system, Mother makes IXPE steady and continuous process of sheet extrusion, ensure the material plasti-cizing distributed evenly, easy to control the temperature.

3、Foaming:

A.Horizontal Foaming Oven

Foaming oven adopts the latest enhanced furnace ,Oven divided into three parts: preheating stage,coil stage, furnace whole length 23meters, high ceiling 5.5 meters, width 3.5 meter.,equipped imported brand high precise burner,Ensure accurate temperature control, can produce XPE, IXPE, rubber and foam products.

1, Low energy consumption: The preheating period, crosslinking made larger changes, meet the technological requirements, reduce the heat capacity of space and energy consumption. , gas consumption and a two-stage furnace.

2, Wide range of production processes: Heat distribution in the furnace, overcome the defects of unreasonable distribution of heat in the furnace,In accordance with the work of the IXPE foam thermal requirements, making the IXPE foam over a relatively wide range, expansion ratio at 5-35 times, foam full, continuous and stable.

3, The output is big: In the current domestic production of foam furnace, our three - stage production of the largest and the largest 200KG/H above, and IXPE foam more detailed than the two - stage gasifier.

B.The vertical Oven

The line includes coiling device, feeding traction device, net belt tensioning device, net belt driving device, preheating furnace body, vertical furnace body, widening device, etc.

Features: uniform heating, small heat loss, large capacity, low energy consumption, simple operation.

The irradiated products are widely used in the fields of electronics, automobile, architecture, medicine, buffer packaging, sports and leisure, etc.

One of the floor mat, balance layer after electronic irradiation, environmental protection non-toxic, anti-aging, corrosion; Independent closed-hole structure, effectively prevent moisture erosion of the floor; Excellent sound insulation performance, can reduce the noise spread between floors; Improve the comfort of your feet during use.

4、Rewinding auxiliary equipment:

The whole length of downstream line is 20m, as from front to back order, it is passed 5 roller calibration unit,air cooling system,smooth surface dealing device,automatic correction trimming device,haul off unit,double position collector.The above three parts, foam extrusion, rolling length of 60 meters.

5. Electronic irradiation rewinding and rewinding system: IXPE electronic crosslinked foaming coils need to undergo electronic irradiation before foaming. This equipment is a complete set of auxiliary equipment before the coils enter the electron accelerator room, including coiling device, traction machine, coiling storage, deviation correction device, coiling storage, coiling machine, etc.

Features: with the electronic accelerator electronic irradiation setting of the winding speed, high degree of automation;The multi-point tension control unit guarantees the stability of the sheet tension.Equipped with the brand process correction system, effectively ensure the integrity of the sheet.

XPE交联聚乙烯发泡生产线

XPE Coil Foaming Extrusion Line



XPE(IXPE)是一种自由式连续发泡的材料。表面光洁、泡孔密闭、独立、均匀、不吸水的软质材料。和其它类似产品相比较，其性能更加优良，特别是在环保、阻燃、绝缘、防水、防潮、减震、缓冲、回弹、保温、隔热、耐候性、耐老化性、耐药品性、质轻、易加工成型、无公害等方面是其它材料无法同时兼备的，所以XPE(IXPE)作为内衬芯材、外包装材被广泛应用到汽车内饰、体育休闲、旅游用品、包装、冷冻、建筑、家庭装饰、公共场所装饰、以及鞋材、箱包、摩擦材料、农林水产、海洋航海工业、儿童玩具、医疗保健及各种日用百货行业等领域。

XPE发泡炉性能优点：

- 1、将预热，交联段做了较大的改变，在满足工艺要求的情况下，减小了热容空间。同时又节省了能源。
- 2、产量大。在目前国内生产的发泡炉中，我们的三段炉产量最大（最大200公斤/小时以上）。而且XPE泡孔比两段炉要细密。燃气用量与两段炉相当。
- 3、发泡段的墙板上设置了观察孔。同时在发泡炉出口处设置了挡板结构，根据生产制品的情况来调整炉口尺寸，从而达到节能的效果。
- 4、发泡倍率最大可达35-40倍。

XPE(IXPE) is a kind of free-style continuous foaming material. The surface is bright and clean, bubble hole is airtight, independent, even, not bibulous soft qualitative material. Compared with other similar products, its performance is more excellent, especially in environmental protection, flame retardant, insulation, waterproof, moisture-proof, shock absorption, buffering, resilience, heat preservation, heat insulation, weather resistance, aging resistance, drug resistance, light weight, easy processing and molding, pollution-free and other aspects are other materials can not simultaneously. Lining so XPE (IXPE) as core material and packing material has been widely applied to automobile interior trim, sports leisure, tourism supplies, packaging, refrigeration, building decoration, home decoration, public, as well as shoes, bags, friction materials, agriculture, forestry and fisheries, Marine navigation industry, children's toys, health care, and various kinds of general merchandise industry, and other fields.

Performance advantages of XPE foaming furnace:

The preheating and cross-linking sections are greatly changed, and the heat capacity space is reduced when the process requirements are met. It also saves energy.

Large output. Among the foaming furnaces produced in China at present, our three-stage furnaces produce the maximum output (maximum 200kg/h or more). And XPE bubble hole than two-stage furnace is closer. The gas consumption is equal to that of the two furnaces.

Observation holes are set on the wall board of the foaming section. At the same time, a baffle structure is set up at the outlet of the foaming furnace to adjust the size of the hearth according to the production of products, so as to achieve the effect of energy saving.

The foaming rate can be as high as 35-40 times.

主要技术参数 Main technical parameters

挤出机 Extruder	JWS150/28	JWS170/28	JWS180/28
螺杆转速 Screw speed Max	10-30	10-30	10-30
最大挤出量 Max output(KG/H)	180-200	200-240	320-350
制品宽度 Width(mm)	1100-2000	1100-2200	1100-2200
制品厚度 Thickness(mm)	2-15	2-15	2-15
主电机功率 Power of main motor(KW)	132	160	185
总装机功率 Total power(KW)	317	380	420

备注：以上规格参数如有变更，恕不另行通知。Note: The specifications are subject to change without prior notice.

双螺杆免干燥排气型PET/PLA片材生产线

Twin Screw Dryer-free Vented PET/PLA Sheet Extrusion Line

常州金纬推出的双螺杆免干燥排气型PET片材生产线具有低能耗、工艺简单，设备使用维护方便的特点。其特有的螺杆组合结构有效的减少了PET树脂的粘度降，对称式薄壁型辊筒提高了冷却效率同时提升了产能和片材品质，多组分喂料装置可合理的控制新料、回料、色母等的比例，所生产的片材可用于吸塑印刷包装等领域。

Changzhou JWELL develops the parallel twin screw extrusion line for PET sheet, this line equipped with degassing system, and no need drying and crystallizing unit. The extrusion line has the properties of low energy consumption, simple production process and easy maintenance. The segmented screw structure can reduce the viscosity loss of PET resin, the symmetrical and thin-wall calender roller highten the cooling effect and improve the capacity and sheet quality. Multi components dosing feeder can control the percentage of virgin material, recycling material and master batch precisely, the sheet is widely used for thermoforming packaging industry.



主要技术参数 Main technical parameters

机型 Model	共挤线 Multi layer	单层线 Single layer	高效 Highly-efficient
挤出机规格 Extruder specification	JW75&36/40-1000	JW75/40-1000	JW95&52/44-1500
制品厚度 Thickness of the product	0.15-1.5mm	0.15-1.5mm	0.15-1.5mm
主电机功率 Main motor power	110kw/45kw	110kw	250kw/55kw
最大挤出产量 Max extrusion capacity	500kg/h	450kg/h	800-1000kg/h

备注：以上规格参数如有变更，恕不另行通知。Note: The specifications are subject to change without prior notice.

PP/PS片材生产线

PP/PS Sheet Extrusion Line

PP/PS片材生产线

PP/PS片材生产线是上海金纬提供的众多设备中属于较简单且标准的机器，该生产线具有产量高、塑化好，操作方便且设备运行稳定的优点。

PP/PS sheet extrusion line

PP/PS sheet extrusion line is one kind of simple and standard machine among the sheet lines provided by Shanghai JWELL, this line has the advantages of high capacity, good plasticization, easy operation and stable running.

主要技术参数 Main technical parameters

机型 Model	JW150/120/90-1800	JW150/60-1200	JW130/60-1000	JW120-1000	JW100-800
片材宽度 Width	1500mm	1000mm	900mm	800mm	600mm
片材厚度 Thickness	0.3-2mm	0.3-2mm	0.3-2mm	0.2-2mm	0.1-0.8mm
生产能力 Capacity	800-1000kg/h	800kg/h	550-600kg/h	350-400kg/h	200-250kg/h
设计线速度 Designed line speed	60m/min	40m/min	30m/min	25m/min	20m/min
辊筒直径 Calendar diameter	Ø900mm	Ø700mm	Ø600mm	Ø500mm	Ø400mm

备注：以上规格参数如有变更，恕不另行通知。Note: The specifications are subject to change without prior notice.

PP/PS吸塑片材、PP文具片 PP/PS thermoforming sheet、PP stationery sheet

PP/PS单层片材、PP/PS共挤双色片材，PP双面高透明片材等用于吸塑包装行业的片材。PP透明片材、磨砂片材（粗砂、细砂）、双色片材等用于文具包装行业的片材。

PP/PS single-layer, co-extrusion two-color, double-side transparent sheets are used in thermoforming and packing industry. PP transparent sheet, dull polish sheet (coarse and fine), two-color sheet and some other sheets are used in stationery industry.

PP发泡片材 PP foaming sheet

PP发泡片材主要文具领域的文件夹等，包装领域的隔板板等，以及汽车内饰领域的遮光板、隔音板、行李架、内装饰件、盖子、箱体等。

PP foaming sheet is mainly used for folder of stationery industry and separation plate of packaging field, also is used for producing visor, acoustic panel, luggage rack, interior decoration parts, cover, and box etc. in car interior decoration industry.

PS导电片 PS electricity conductive sheet

主要应用于半导体电子电脑通讯等产品，特别应用于要求无尘、无静电、放电防护及遮蔽电磁波/无线电频率干扰之配件或设备的包装。

Mainly used for packing of semi-conductive electric components, computer products which require no dust, not static electricity, no radio frequency or facilities.



APET PETG CPET PLA片材生产线

APET, PETG, CPET, PLA Sheet Extrusion Line

APET、PETG、CPET单层及多层共挤片材生产线 APET, PETG, CPET single-layer or multi-layer sheet extrusion machine

是目前国内技术先进、工艺成熟、设备稳定的片材生产线之一，与国内同类设备相比，综合效能高30%以上，此生产线同时也可用于生产PS、PP、PE等片材制品。

It's one of the most advanced production lines with matured technology and stability in China. Compared with other same kind equipment, it's over 30% higher in overall efficiency. Line is suitable for PS, PP, PE as well.

主要技术参数 Main technical parameters

机型 Model	共挤线 Multi layer	单层线 Single layer	高效Highly-efficient
挤出机规格 Extruder specification	JW120/65-1000	JW120-1000	JW120-1500
制品厚度 Thickness of the product	0.20-1.5mm	0.15-1.5mm	0.15-1.5mm
主电机功率 Main motor power	110kw/45kw	110kw	160kw
最大挤出产量 Max extrusion capacity	500kg/h	450kg/h	800kg/h

备注：以上规格参数如有变更，恕不另行通知。Note:The specifications are subject to change without prior notice.

PETG片材 PETG sheet

PETG俗称低温PET，产品具有高光泽、高透明、有优良的阻隔性、自粘性的新型环保包装材料。可用于胶水粘合、高周波加工。PETG is called low temperature PET, it's a new environment-friendly packing material with features such as high luster, good transparency, excellent barrier property, self-adhesion, which is used for glue bonding and high-frequency processing.

CPET片材 CPET sheet

CPET是一种改性PET，具有耐高温的特性，通常用于微波炉烤盘等。

CPET is a kind of modified PET. With good resistance to high temperature, it is usually used for package in microwave oven.

PET立体光栅片 PET stereoscopic optical grating sheet

广泛适用于化妆品、药品、烟酒包装及一般商品等三维防伪外包装以及文具、挂件、宣传广告、海报、各式卡片、吊卡等领域。It can be used as top grade package for cosmetics, medicine, tobacco & alcohol and common goods such as stationery, advertisements, posters and all kinds of cards.

PLA片材 PLA sheet

聚乳酸PLA是可降解树脂，可用于水果、蔬菜、鸡蛋、熟食和烘烤食品的硬包装，也可用于三明治、饼干和鲜花等商品的包装。

PLA is a kind of line shape Aliphatic Polyesters. PLA can be used in rigid package of fruits, vegetables, eggs, cooked food and roast food, also can be used for packaging of sandwich, biscuit and some other packages like fresh flower.



PLA（聚乳酸）环保可降解片材生产线

PLA (Polylactic Acid) Environmentally Friendly Degradable Sheet Production Line

PLA（聚乳酸）是一种新型的生物基及可再生生物降解材料，使用可再生的植物资源（如玉米、木薯等）所提出的淀粉原料制成。聚乳酸的生产过程无污染，而且产品可以生物降解，实现在自然界中的循环，因此是理想的绿色高分子材料。聚乳酸的热稳定性好，加工温度170~230℃，有好的抗溶剂性，由聚乳酸制成的产品除能生物降解外，生物相容性、光泽度、透明性、手感和耐热性好，还具有一定的抗菌性、阻燃性和抗紫外性，因此用途十分广泛，可用于水果、蔬菜、鸡蛋、熟食和烘烤食品的硬包装，也可用于三明治、饼干和鲜花等商品的包装。

PLA (Polylactic Acid) is a novel biobased and renewable biodegradable material made from starch raw materials proposed by renewable plant resources such as corn and cassava. The production process of PLA is non-polluting, and the product can be biodegraded to achieve circulation in nature, so it is an ideal green polymer material. PLA has good thermal stability, processing temperature of 170-230°C, with good solvent resistance. Products made of PLA have the advantage of biodegradability, gloss, transparency, good feel and heat resistance. It also has good antibacterial, flame retardant and UV resistance, so it can be used in rigid packaging of fruits, vegetables, eggs, cooked foods and baked goods. It can also be used for the packaging of sandwiches, biscuits and flowers, etc.



主要技术参数 Main technical parameters

种类 Species	单层线 Multi layer	单层线 Multi layer	单层线 Multi layer	单层线 Multi layer	单层线 Multi layer
挤出机规格 Extruder specification	CJWH75/40-1000	CJWH85/40-1000	JWS120-1000	JWS130-1000	JWS150-1200
制品厚度 Product thickness (mm)	0.2-1.5	0.2-1.5	0.2-1.5	0.2-1.5	0.2-1.5
主电机功率 Main motor power	132	160	132	160	220
最大挤出产量 Max capacity (kg/h)	450	550	500	600	800

备注：以上规格参数如有变更，恕不另行通知。Note: The specifications are subject to change without prior notice.

改性片板材挤出生产线

Modified Plastic Sheet & Plate Extrusion Line

采用积木式同向平行双螺杆挤出机。一步法工艺，减少造粒环节。产品可用于电子、箱包、汽车、建材等领域。

Adopt building block type co-rotating parallel twin screw extruder, which can compound material and produce the sheet by one step without pelletizing production. The sheet can be used in the industry of electronics, bags and suitcase, automobile, building material, and so on.

优点：无需造粒，减少了冷却、切粒、包装以及再加热过程，为工厂节约厂房空间、包装成本和电费，并大大提高了生产效率。
Advantage: no need to pelletizing, reduce some procedure of cooling, granulating, packaging and re-heating. Saving factory space, and reducing the cost of packaging and electricity consumption for manufacturers, meanwhile, increasing the productivity.

主要技术参数 Main technical parameters

用途 Application	玻纤Glass fiber、钙粉CaCO ₃ 、炭黑Carbon black、增粘Tackify		
机型 Model	JWE65/36-1000	JWE75/40-1200	JWE95/44-2200
制品规格 Products width	800mm	1000mm	2000mm
制品厚度 Products thickness	0.2-2mm	1-6mm	2-10mm
设计产量 Capacity	600kg/hr	800kg/hr	1200kg/hr

备注：以上规格参数如有变更，恕不另行通知。Note: The specifications are subject to change without prior notice.



PC、PMMA光学片材生产线

PC PMMA Optic Sheet Extrusion Line

PC、PMMA光学片材生产线

为了满足市场的需要，上海金纬凭借先进的工艺技术及装备向用户提供了光学级片材生产线。根据原料的流变性设计的专用螺杆和精密的计量泵系统和模具保证了熔体的均匀稳定和片材优异的光学性能；精密的压光系统给片材的机械物理性能提供了保障。

To meet the demands of market, Shanghai JWELL supply customer PC PMMA optical sheet extrusion lines with advanced technology, the screws are specially designed according to the rheological property of raw material, precise melt pump system and T-die, which makes the extrusion melt is even and stable and the sheet has excellent optical performance. Precise calender system guarantees the mechanical & physical properties of sheets.

主要技术参数 Main technical parameters

机型 Model	JW100-1300	JW120-1500	JW130-1600
制品宽度 Production width	1000mm	1200mm	1300mm
制品厚度 Production thickness	0.05-0.50mm磨砂片	0.125-1.2mm透明片	0.175-2.0mm透明片
挤出机规格 Extruder model	JWS100/38	JWS120/38	JWS130/35
设计挤出产量 Designed capacity	250kg/h	400kg/h	500kg/h

备注：以上规格参数如有变更，恕不另行通知。Note:The specifications are subject to change without prior notice.



PC、PMMA光学片材

产品主要应用于汽车工业；电子、电器工业的薄膜开关；电脑、手机、商务通的液晶显示屏；太阳镜、太阳帽、镀膜、防护面罩；特种印刷；医药包装等领域。

PC PMMA optic sheet

It is mainly used in automotive industry, film switch of electronics, LCD for computer, mobile, sunglass, helmet, special printing, medicine packing and so on areas.

EVA/POE/TPO汽车隔音垫生产线

EVA/POE/TPO Automotive Soundproof Sheet Extrusion line

汽车隔音垫（阻尼止震垫）是采用EVA、TPO、PVC等原料，加高填充无机物制成的高密度片材。使用时贴在钣金上，可以从源头制止噪音的产生。并隔绝金属对声音的传导。主要应用于汽车的车身机盖、车门、后备舱、车顶、翼子板等位置，还能起到加强、隔热效果。厚度0.6-8mm，宽度1000mm-3000mm。

Car Sound Insulation Pad(Vibration Damping Pad) is made of EVA, TPO, PVC and high filling inorganic. It is placed directly on the metal part, which eliminates the noise from the source and avoid the noise transmission in the metal. It is mainly used in car cover, door, luggage room, top part, fender part, which also help to improve the strength and heat insulation. Regular thickness is from 0.6 to 8mm and width from 1000mm to 3000mm.



TPO/TPU合成革生产线

TPO/TPU Composite Leather Extrusion Line

聚烯烃热塑性弹性体（TPO）生产的合成革卷材（复合卷材），环保、耐磨、耐热，广泛应用于汽车内饰材料，包括仪表板蒙皮、内饰板蒙皮、车内地胶、尾箱垫、脚垫材料。合成革产品厚度规格0.2-3mm，宽度1000-2000mm。

Polyolefin thermoplastic elastomer(TPO) composit leather roll(coating roll) has the advantages of enviroment friendly and abrasion and heat resistance. It has been used widely in the field of car inner decoration, i.e. instrument board skin, inner decoration skin, in-car flooring, car rear tank flooring, foot pad material. Its regular thickness is 0.2-3mm with width 1000-2000mm.

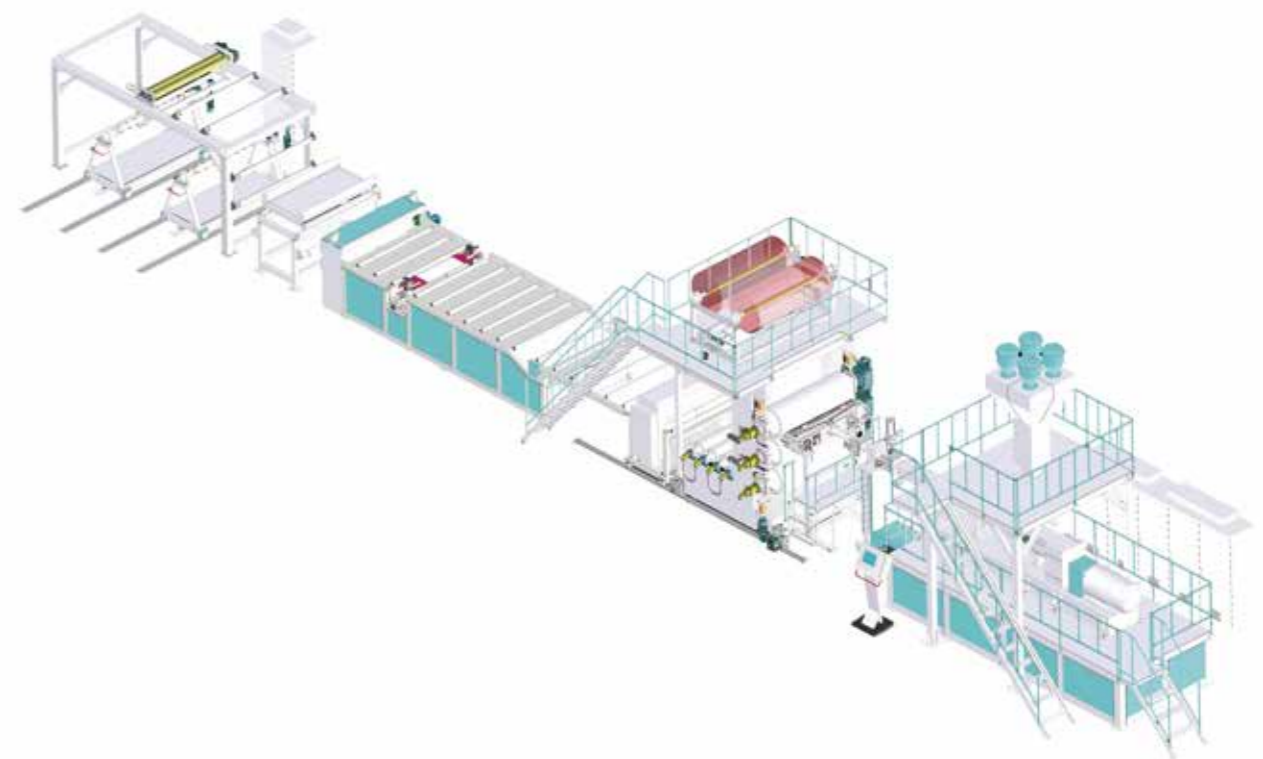

ABS、HIPS、PMMA冰箱板、洁具板生产线

ABS, HIPS, PMMA Refrigerator Plate, Sanitaryware Plate Extrusion Line

ABS、HIPS、PMMA冰箱板、洁具板生产线

上海金纬提供国内领先的大产量低能耗板材挤出生产线，具备集中供料系统及机械手自动堆垛装置，实现了高程度的自动化生产功能，大大的降低生产成本并提高了产品品质。该生产线深受广大客户的欢迎。

ABS, HIPS, PMMA refrigerator plate, sanitaryware plate extrusion line

Shanghai JWELL provides the leading plate extrusion lines with large output and low energy consumption, the lines are equipped with concentrated material feeding system and automatic piler, its automatic production function reduce the cost of processing and improve product quality highly. This extrusion line is popular in our customers.

冰箱板 Refrigerator board

主要用于冰箱冰柜门胆、内胆、抽屉、接水盘、饮水机等。

It has wide application in production of refrigerator door and inner gallbladder, drawers, water dispensers, etc.

洁具板 Sanitaryware plate

用于卫浴产品如：浴缸、淋浴房、蒸汽房、洗脸槽。

It is widely applied in the field of bath products, such as the bathtub, the shower cabinet, the vapor room, washing bowl, etc.

广告板 Advertising board

主要应用于：指示导向牌、胸标牌、机械标牌、广告装潢、室内装饰等。

This board is mainly used in guiding board, machinery sign, advertisement decoration, indoor decoration and so on.

箱包板 Baggage plate

主要用于各种拉杆箱、行李箱、休闲包等箱包。

It is mainly applied in field of draw-bar boxes, luggage cases, recreation bags, etc.

汽车板 Car plate

主要用途：汽车车顶、仪表板；座椅靠板、车门板、窗框；摩托车、沙滩车、代步车、高尔夫球车等外壳。

It is mainly used for producing tops of cars and buses, instrument boards, backrest, car doors, window frames, shells of the motorcycles, golf vehicles, etc.

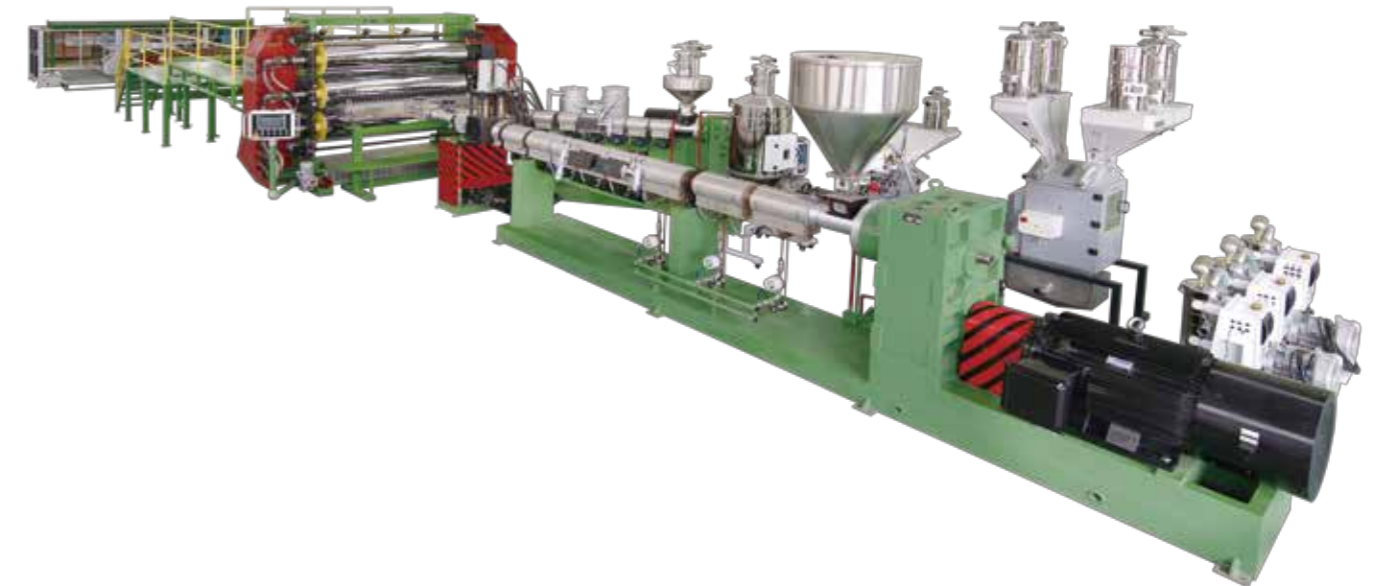

主要技术参数 Main technical parameters

机型 Model	JW160/60-2200	JW130/60-2000	JW120/60/45-1900	JW130/70/60-2700
适用原料 Suitable material	ABS、HIPS	ABS、HIPS	ABS、HIPS	ABS、PMMA
挤出机规格 Extruder model	JWS160/38,60/35	JWS130/38、60/35	JWS120/38,60/35,45/35	JWS130/38,70/35,60/35
共挤分层形式 Feed form	A/B,A/B/A	A/B,A/B/A	A/B/C	A/B/C/B/A
制品宽度 Products width	2000mm	1800mm	1700mm	2100-2500mm
制品厚度 Products thickness	1-6mm	1-6mm	1-6mm	2-8mm
最大挤出产量 Designed capacity	1500Kg/h	1200kg/h	550Kg/h	700Kg/h

备注：以上规格参数如有变更，恕不另行通知。Note:The specifications are subject to change without prior notice.

PP、PE、ABS、PVC、PVDF厚板生产线

PP, PE, ABS, PVC, PVDF Thick Plate Extrusion Line

PP厚板生产线 PP thick plate extrusion line

PP厚板，可广泛用于化学工业、食品行业、防腐行业、净化行业、环保设备生产行业。2000mm宽PP厚板生产线是金纬新开发的领先于同行的稳定的生产线。

PP thick plate, It is an environment-friendly product and is widely applied in chemistry industry, food industry, anti-erosion industry, environmentally-friendly equipments industry, etc. PP thick plate extrusion line of 2000mm width is a newly developed line which is the most advanced and stable line compared with other competitors.

PE厚板生产线 PE thick plate extrusion line

聚乙烯板材广泛应用于化工、电力等工业上。HDPE板还可作为工程塑料应用在机械、化工等设备上，广泛用于制造冰球场墙板。

PE plate is widely applied in chemical and electric power industries. HDPE plate, known as engineering plastics, is used in mechanical and chemical equipments as well as ice hockey ring walls.

PVC厚板生产线 PVC thick plate extrusion line

硬质PVC厚板广泛用于化工、石油、电镀、水净化处理设备、环保设备、矿山、医药电子、通讯、防腐蚀容器、设备电气的护罩，灯箱，广告装潢等行业。

Rigid PVC thick plate is widely used in chemical industry, petrol, electroplating, water purifying equipments, environment-friendly equipments, lamp house and advertisements, etc.

PVDF板材生产线 PVDF plate extrusion line

PVDF板材是用聚偏氟乙烯树脂经过高温挤出成型的纯净板材，挤出过程不含添加剂（如紫外稳定剂、热稳定剂、软化剂、润滑剂或阻燃剂等添加剂）。广泛用于石化、电力、冶金、造纸、纺织、制药和原子能工业等诸多工业领域，特别适用于纯水系统和半导体行业中纯净化学试剂的传输。

PVDF plate is a pure plate extruded with Polyvinylidene fluoride resin, there is no any additive (such as UV stabilizer, heat stabilizer, plasticizer, lubricant or flame retardant etc.). The plate was widely used in petrification, electricity, metallurgy, paper making, spinning, medicine and atomic energy industry and other industries, especially, for the application of conveying the pure chemical agent used in cleaning water system and semiconductor industry.



主要技术参数 Main technical parameters

机型 Model	JW120-1600	JW150-2100	JW170-2600	SJZ80/156-1500
适用原料 Suitable material	PP、PE、ABS、PVDF	PP、PE、ABS	PP、PE、ABS	PVC
制品宽度 Products width	1220mm	1500mm	2000mm	1220mm
制品厚度 Products thickness	3-30mm	3-30mm	3-30mm	3-30mm
设计挤出产量 Designed capacity	350Kg/h	500Kg/h	700kg/h	400 Kg/h

备注：以上规格参数如有变更，恕不另行通知。Note: The specifications are subject to change without prior notice.



PC、PMMA、GPPS塑料片板材机组

PC, PMMA, GPPS Plastic Sheet & Plate Extrusion Line

PC耐力板适用范围: 园林、游艺场所奇异装饰及休息场所的廊亭; 商业建筑的内外装饰品, 现代城市楼房的幕墙; 航空透明集装箱、摩托车前风挡、飞机、火车、轮船、汽车、汽船、潜艇及玻璃军警盾牌; 电话亭、广告路牌、灯箱广告展示展览的布置; 高速公路及城市高架路隔音屏障。

Applicable scope of PC endurance board: Garden, recreation place, decoration and the corridor pavilion; Internal and external ornaments in the commercial building, curtain wall of the modern urban building; transparent container of aviation, the windscreen before the motorcycle, the plane, the train, the steamer, the submarine, army and police's shield, the telephone booth, advertising signpost, the advertisement of the lamp houses, the expressway and over-head way of the city partition protective screen.

PMMA板材(亚克力板材/GPPS板材)

产品分类: 普通PMMA板材主要用于广告、装饰、装潢、工艺制品、标本标牌等; 电镀板用于真空电镀塑料镜片; 照明类导光板用于超薄灯箱、LED平板显示灯和海报架等广告装饰方面; 液晶类导光板用于电脑、电视等液晶显示组件。金纬提供的板材挤出生产线可用于加工PMMA或PC扩散板。

PMMA board (Acrylic board/GPPS board): Application of product: common PMMA plate is mainly used in the field of advertisement, decoration, art ware, escutcheon and specimen etc; the electroplated plate is used for plastic mirror; Light panel is used for ultra light box, flat panel display lamp of LED, poster stand and advertising decoration etc. LCD panel can be used for the display of computer and television. JWELL'S plate extrusion line is suitable for producing the PMMA or PC diffusion plate.



主要技术参数 Main technical parameters

型号 Model	JW130/38-2200	JW120/38-1400
适用原料 Material	PC、PMMA、GPPS	PC、PMMA、GPPS
制品宽度 Products Width	2200mm	1400mm
制品厚度 Products Thickness	1.5-10mm	1.5-10mm
挤出机规格 Extruder Specification	Ø130/38; Ø45/30	Ø120/38
最大挤出产量 Capacity (Max.)	550Kg/h	450Kg/h

备注: 以上规格参数如有变更, 恕不另行通知。Note: The specifications are subject to change without prior notice.



PC、PP、PE中空格子板生产线

PC, PP, PE Plastic Hollow Cross Section Plate Extrusion Line

PC阳光板应用:

- 办公楼、大厅、商场、体育场馆、公用设施的采光顶
- 车站、停车场、凉亭、休息厅走廊的雨棚
- 高速公路及城市高架路隔音屏障

APPLICATION

- Construction of sunroof in buildings ,halls, shopping center ,stadium ,public places of entertainment and public facility.
- Ring shield of bus stations ,garages, pergolas, corridors.
- Transparent shields for security forces in nursery schools airports, factories.

PP格子板应用:

- PP中空格子板因具有材质轻，强度高，防潮，良好的环保性能和二次加工性能，可加工成周转箱，包装箱等

APPLICATION

- The pp hollow cross section plate is light and high strength ,moistureproof good environmental protection and refabrication performance.
- Can be processed into the reusable container,packing case, clapboard ,backing plate ,and culet.

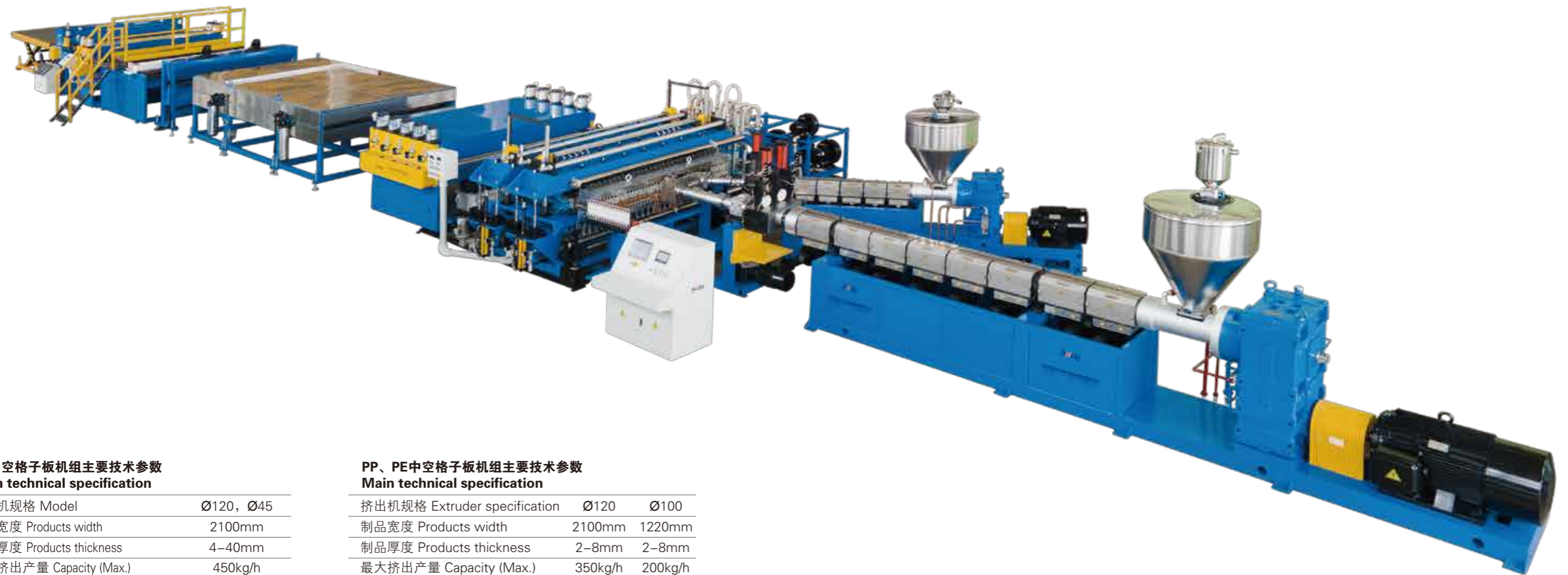
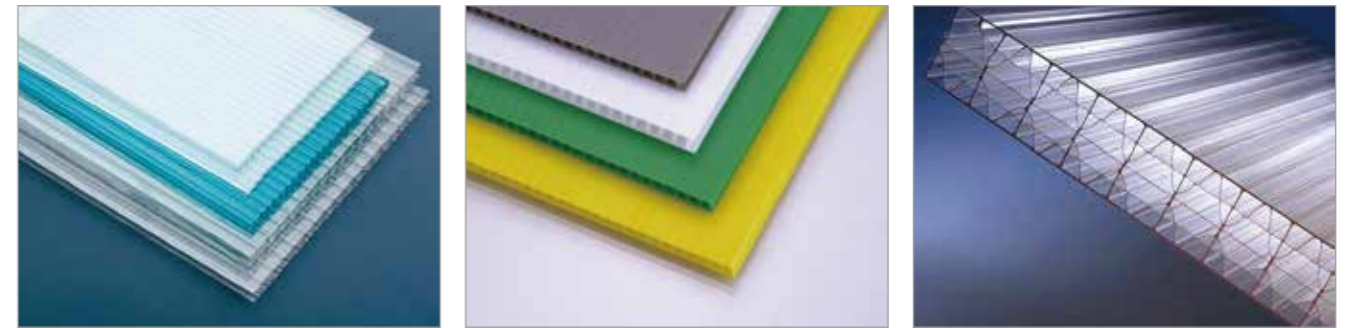

PC中空格子板机组主要技术参数 Main technical specification

挤出机规格 Model	Ø120, Ø45
制品宽度 Products width	2100mm
制品厚度 Products thickness	4-40mm
最大挤出产量 Capacity (Max.)	450kg/h

备注: 以上规格参数如有变更, 恕不另行通知。
Note: The specifications are subject to change without prior notice.

PP、PE中空格子板机组主要技术参数 Main technical specification

挤出机规格 Extruder specification	Ø120	Ø100
制品宽度 Products width	2100mm	1220mm
制品厚度 Products thickness	2-8mm	2-8mm
最大挤出产量 Capacity (Max.)	350kg/h	200kg/h

备注: 以上规格参数如有变更, 恕不另行通知。
Note: The specifications are subject to change without prior notice.

PP聚丙烯石粉环保片材生产线

PP and Calcium Powder Environmental Protection Sheet Extrusion Line

PP+ 石粉环保片材生产线

金纬机械研制开发的PP+石粉环保片材生产线，采用三台挤出机三层或四层共挤法，选用金纬新设计的PP+石粉专用排气式螺杆结构，PLC电脑控制和自动测厚仪跟踪检测，从而有效利用石粉比例，在降低片材原料成本的基础上，又确保片材的综合物理性能和后续可加工性能，使生产线产能指数达到良好状态，是目前国内先进的片材机组之一。

PP+CaCo3 environmentally-friendly sheet extrusion line

It developed by Jwell company uses the three extruders for 3 or 4 layers co-extrusion. This line adopts the Jwell latest designed PP+CaCo3 vented screw and the PLC computer controlling device and automatic thickness detection device so that the machine can maximize the percentage of the CaCo3 in the sheet production to reduce the cost of the sheet and the sheet produced can gain the good physical properties and further processing abilities. It is the most advanced sheet machine in China.

主要技术参数 Main technical parameters

机型 Model	JW-120/100/45-1500
分层形式 Layer structure	A/B/C/A
制品宽度 Products width	1320mm
制品厚度 Products thickness	0.3-1mm
最大挤出产量 Designed capacity	800Kg/h

备注：以上规格参数如有变更，恕不另行通知。Note: The specifications are subject to change without prior notice.



PP木粉/竹粉/麻纤维板材生产线

PP and Wood Powder, Bamboo Powder and Fiber Composite Sheet Extrusion Line

PP+ 木粉板材/PP+ 麻纤维板材生产线

PP+ 木粉、PP+ 麻纤维复合片材生产线，采用锥形双螺杆挤出机挤出，配以特殊工艺手段，是金纬推出的又一个国内领先的生产线机组。此复合片材具有深成型、深拉伸，与各种面料一次热压成型复合的制品，边角余料可回收利用等特点，被广泛应用于高档汽车内饰件、顶棚、后搁物板、行李箱基材及宾馆、餐厅、娱乐场所的装潢。

PP+ fiber sheet/PP+ wood powder sheet extrusion line

This production line adopts conical twin-screw extruder, with specially processing method, which is another most advanced technology in China. This product features of well-shaped, easily processed, recycling and reuse of the off cutting once-complexion with other material of sheet by hot pressing. It can be widely applied in the decoration of automobile ornaments, ceiling, booth, suitcase, hotel, restaurant, entertainment area and etc.

主要技术参数 Main technical parameters

机型 Model	SJZ92/188	SJP140/25
制品厚度 Products thickness	1-6mm	2-8mm
制品宽度 Products width	1200-1600mm	1500-2000mm
最大挤出量 Max output capacity	350-450kg/h	500-600kg/h
主电机功率 Main motor power	110kw	160kw

备注：以上规格参数如有变更，恕不另行通知。Note: The specifications are subject to change without prior notice.



PVC地板革/装饰片材/仿大理石板挤出生产线

PVC Floor Leather/Decoration Sheet/Lamination Marble Board Extrusion Line

PVC地板革具有耐磨、耐腐、防滑、防渗、阻燃的性能，广泛用于机车、宾馆、酒店、娱乐厅、展馆、家庭。

可以根据客户的要求，配置不同的设备组件，用于生产单层、多层复合产品；也可增加放卷装置，生产内增强产品或表面复合无纺布、PVC装饰膜等的产品。

PVC Floor leather has the performance of anti-friction, corrosion resistance, skidproof, impermeable and inflaming retarding, and is widely used on auto, hotel, amusement place, exhibition hall, house, etc.

The structure of this production line is simple, and convenient to operation. According to customers' requirement, equipped with different components, used for producing single layer, multi-layer composite production and also can be equipped with unreeling unit, used for producing inner strengthen production or surface compound non-woven fabrics and PVC decoration film, etc.

PVC装饰片材特点：一般可以分为两大类，透明和非透明材料，是室内外广告的载体。可以用单台或多台挤出机进行单层或多层共挤出成型。

Character of PVC decoration sheet: decoration sheet can be divided into two kinds: transparent and non-transparent material. Single layer or multi layer sheet could be produced.

UV 仿大理石板

板材表面覆仿大理石纹薄膜，或者热转印仿大理石纹并UV固化处理，良好的抗划伤性，耐刮擦性；板材花色、品种多样，施工方便；

在室内墙体装潢中替代大理石等天然石材，良好的耐老化、抗紫外线、耐黄变，绿色环保、无辐射。

UV Imitation Marble Board

Board surface coat imitation marble film, or laminate imitation marble and through curing treatment, good anti scratch, antiscratch resistance; Board with variety of color, it's convenient to construct; Instead of marble etc. natural stone in the interior.



主要技术参数 Main technical parameters

型号 Type	双层 Double layers	三层 Three layers
制品宽度 Products width	1500-2000mm	2000-3000mm
挤出机规格 Extruder specification	SJZ65/132 - SJZ80/156	SJZ65/132 - SJZ80/156 - SJZ65/132
最大挤出量 Max output capacity	500-550kg/h	600-750kg/h
主电机功率 Main motor power	37kw/55kw	37kw/55kw/37kw

备注：以上规格参数如有变更，恕不另行通知。Note: The specifications are subject to change without prior notice.



EVA/POE太阳能封装膜生产线

EVA/POE Solar Film Extrusion Line

EVA/POE太阳能封装膜生产线 EVA/POE solar film extrusion line

全自动的称重式计量装置，保证多种固体、液体添加助剂及原料高精度喂料；低温挤出系统在保证充分混炼塑化的情况下，防止助剂提前固化交联；流延部分的特殊设计，完美的解决了粘辊、剥离问题；独特的在线回火去应力装置；生产线中多处张力控制系统，使富有弹性的片材在冷却、牵引及收卷过程中平稳输送；在线自动测厚和瑕疵检测装置提供了封装膜制品品质的实时反馈。

Automatic gravimetric feeding system makes sure variety of solid, liquid additives and raw materials high-precision feeding. Low-temperature extrusion systems to ensure adequate mixing in the premise of plastination to prevent crosslinking additives. Special design of Casting part give the perfect solution to roller adhibition and water spalling. Special online tempering device to get rid of inner stress. Tension control system ensure the flexible sheets conveying placidly during cooling, pulling and winding process. The on-line thickness measuring and defect inspecting system can provide real-time feedback of the production quality of EVA solar film.

主要技术参数 Main technical parameters

型号 Model	JW130-1200	JW150-2400
适用原料 Suitable material	EVA	EVA
制品宽度 Products width	810mm	2200mm
制品厚度 Products thickness	0.2-0.8mm	0.2-0.8mm
设计线速度 Designed line speed	10m/min	10m/min
挤出产量 Extrusion capacity	250kg/h	400kg/h

备注：以上规格参数如有变更，恕不另行通知。Note: The specifications are subject to change without prior notice.



小型实验机挤出设备

Small Laboratorial Extrusion Equipment

小型试验机挤出设备 Small testing extrusion line

常州金纬提供的小型试验机挤出设备，可完成挤出、流延、制片、拉伸、复合等挤出成型的加工实验。主要应用于各大化工院校、塑料研究所等科研机构的高分子材料的性能加工测试和高分子产品企业的研发部门的新产品开发以及普通塑料制品企业的定制产品打样工作等。

The small testing extrusion lines provided by Changzhou JWELL can meet the demands of extrusion, casting, sheet production, stretching and composite etc. processing test. These lines are used by some Chemical Colleges and Plastics Research Institutes to process and test the performance of the polymer material; It is also for developing new products or making samples and other application in plastic factory's research department.



ASA薄膜生产线

ASA Film Extrusion Line

ASA薄膜是用聚氯乙烯、聚乙烯、聚丙烯、聚苯乙烯以及其他树脂制成的薄膜，用于包装,以及用作覆膜层。塑料包装及塑料包装产品在市场上所占的份额越来越大，特别是复合塑料软包装及建材表面包覆已经广泛应用。

The ASA film is made of PVC, polyethylene, polypropylene, polystyrene and other resins, used for packaging and for laminating. Plastic packaging and plastic packaging products are becoming more and more popular in the market, especially the composite plastic soft packaging and surface coating of building materials.

优点：ASA薄膜因其具有突出的抗老化性能，在屋面瓦领域应用广泛，在屋面瓦加工的同时，可以实现在线热复合，复合厚度均匀，无色差，粘结强度高，克服了传统的共挤ASA复合存在的色差问题，也节约了原料成本。

ASA表面的加工厚度范围：0.05-0.2mm，宽度1500mm，厚度均匀，尺寸稳定。

Advantage: Because of its outstanding anti-aging property, ASA film is widely used in roof tile field. In the process of roofing tile, it can achieve on-line thermal composite, with uniform thickness, no color difference and high bond strength. It overcomes the color difference of traditional coextrusion ASA composite, and also deals with the cost of raw materials. The thickness of the ASA surface is 0.05-0.2mm, width 1500mm, uniform thickness and stable dimension.

主要技术参数 Main technical parameters

机型 Model	JWS90-1500
适用原料 Material	ASA material
制品宽度 Products width	1400mm
制品厚度 Products thickness	0.05-0.15mm
挤出机规格 Extruder specification	JWS90/30
最大挤出量 Capacity (Max.)	150 ~ 180KG/H

备注：以上规格参数如有变更，恕不另行通知。Note:The specifications are subject to change without prior notice.

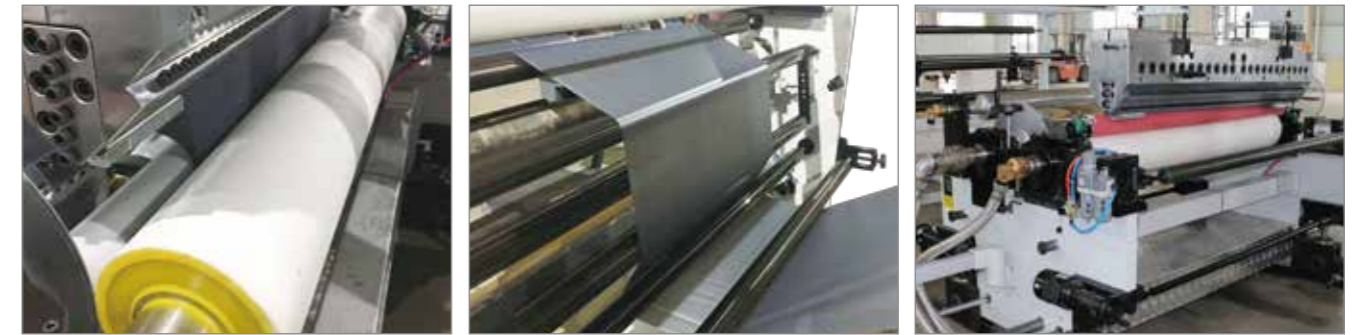

其它的塑料片材生产线

Other Plastic Sheet Extrusion Line

纵向拉伸生产线(MDO) Lognitudinal streching equipment extrusion line

纵向拉伸生产线(简称 MDO)主要应用于 PP、PE 锂离子电池隔膜; PP、PE 卫材透气膜; PP、PE、PET 热收缩包装行业等单向拉伸薄膜领域。

Lognitudinal stretch equipment (short name is MDO) is mainly used for PP、PE lithium electric film; PP、PE breathable film; PP、PE、PET thermo-shrinkage packing industrial, etc single stretching film industrial.



双向拉伸薄膜生产线 Bidirectional pull flim extrusion line

主要用于生产 BOPP BOPS BOPET BOPA 等通用包装薄膜和 PE 双向拉伸电池隔膜、PVDF 双向拉伸太阳能电池隔膜、双向拉伸微孔透气膜等特殊用途薄膜。

The machine is mainly used to produce BOPP, BOPS, BOPET, BOPA etc. packaging film and BOPE battery separating film, also for PVDF biaxially oriented solar film, biaxially oriented microporous breathable film, and other film for special application.



TPU薄膜生产线 TPU film extrusion line

TPU片材和薄膜主要有超透和压纹两种, 主要应用鞋材, 箱包, 医疗。防水, 透气, 绝缘, 反光, 镭射等方面。

TPU sheet and film have two types, one is super-transparent, the other is embossed. They were mainly used in the field of shoe material, luggage, medical treatment, water proof, ventilation, insulation, reflect light, laser, etc.



PE气垫膜(气泡膜)生产线 PE air bubble film extrusion line

可以替代发泡塑胶颗粒填充物之类的防护用品, 为电子产品、化妆品、音像CD等卖家的防护包装首选。

It's widely used in packing items to endure high vibration. PE air bubble film is completely suitable for the protection item made by foamed granules, so it is the first choice for packing electronics, cosmetics and vide CD products.

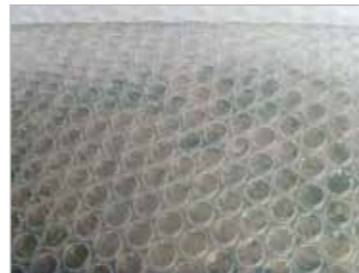

PVC结皮发泡、木塑发泡板材生产线

PVC skinning foaming、WPC foaming board extrusion line

PVC发泡板及木塑发泡板的应用于轮船、飞机、客车、火车车厢、顶蓬、箱体芯层、内部装饰用板和建筑物外墙板、内装饰用板、住宅、办公室、公共场所建筑物隔间、商用装饰架、无尘室用板、吊顶板、家庭厨柜、吊柜和家居。通过油漆印刷、贴膜和热压设备, 可以生产各类仿木制品。

Transportation industrial: Ship, plane. bus, chamber of train, roofing, core layer, inner decoration board. Construction and decoration industrial: outer wall board, inner decoration board, housing, office, public construction board, furniture. cupboard, roofing. Adopting printing, film coating and thermo-embossing equipment, will get all kinds of emulational wooden product.



PE蓄电池隔板生产线 PE battery separating plate extrusion line

隔板蓄电池的重要组成, PE隔板是蓄电池隔板的换代产品, 随着我国汽车行业发展及普及, PE隔板市场将进一步扩大。

It is an important part of battery. PE separating plate is a new style of battery separator. With the development of car industry in China, the market share of PE separating plate will be greatly increased.



单螺杆造粒挤出生产线 Single screw pelletizing extrusion line

采用特殊的螺杆设计及不同配置, 适用于生产PP、PE、PET、PS、ABS、PA、PVC、PC、POM、EVA、PMMA等多种塑料的再生及混色造粒。

This pelletizing extruder has the special screw design and different configuration, it is suitable for the recycling and pelletizing of raw materials such as PP, PE, PET, PS, ABS, PA, PVC, PC, POM, EVA, PMMA and the pelletizing of the raw materials with different colors.

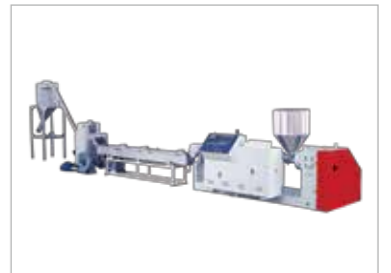

塑料土工格栅生产线 Plastic geogrid extrusion line

产品广泛应用于水利、公路、铁路、煤矿、建筑等工程领域。如用于建坝、护坝、护坡, 防汛防洪网笼, 高速公路、铁路、路基加固, 挡土墙护网、矿井顶网, 由于在工程应用中表现出的优越性能, 以及产品低成本、高效率的特点, 市场前景广阔。

It is widely used in irrigation, highway, railway, mine and building project, for example it's used to build dam, protect dam and slope, protect network of preventing flood, fix the roadbed and etc. The product has a high perspective among the markets because of its effective features.

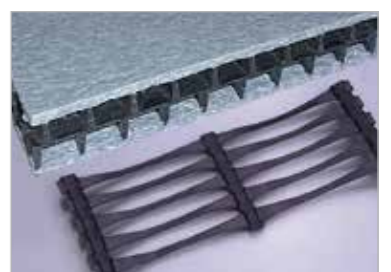

钢材钢卷防锈用PP、PE塑料包装板材生产线

PP、PE plastic packing plate for rust prevention of iron and steel extrusion line

钢卷包装用塑料端护板。塑料保护板、端护板、内外护角圈、端护圈、包装盒、垫片等。金纬也可以提供钢材包装专用三层共挤PE/PP发泡板材生产线。

protection board for steel roll packing. Plastic protection board, terminal protection board, inside and outside angle protection ring, terminal protection ring, packing case, gasket and so on. Jwell can provide three-layer co-extrusion PE/PP foaming board production line only for steel packing.



PP、PE、PVC 蜂窝板生产线 PP, PE, PVC beehive plate extrusion line

应用: 汽车车身、铁路、火车箱体、船舶、化学品储藏罐、以及建筑、高档房屋的装修、隔板、身体防护用品等诸多领域。

It has advantages of low weight, high intensity, heat preservation, sound insulation, anti-erosion, nontoxic and deleterious, and it has the features of energy absorption, vibration decreasing and absorption when impacted.



集中供料系统

Feeding System

集中供料系统是为塑料挤出车间的塑料产品生产而设计的，实现了不间断无人化连续成型作业。可根据需要改变原料品种、多颜色材料的组合使用方式，实现配方工序的自动化。系统能够以全自动方式组合原料成份及状态，能够对所有供料设备的控制，并防止了储料仓内阻塞现象的发生，通过设置中央监控台实现全自动化。

Material centralized feeding system was designed for the plastic product extrusion plant, which can keep working automatically. It can change the raw material and color masterbatch, making up the formulation automatically as per the need of production. The system will make the material components and state automatically, being easy for controlling the material feeding of all production lines, and protecting the material block in the hopper, realizing material feeding automatically by the data setting in the central controlling panel.

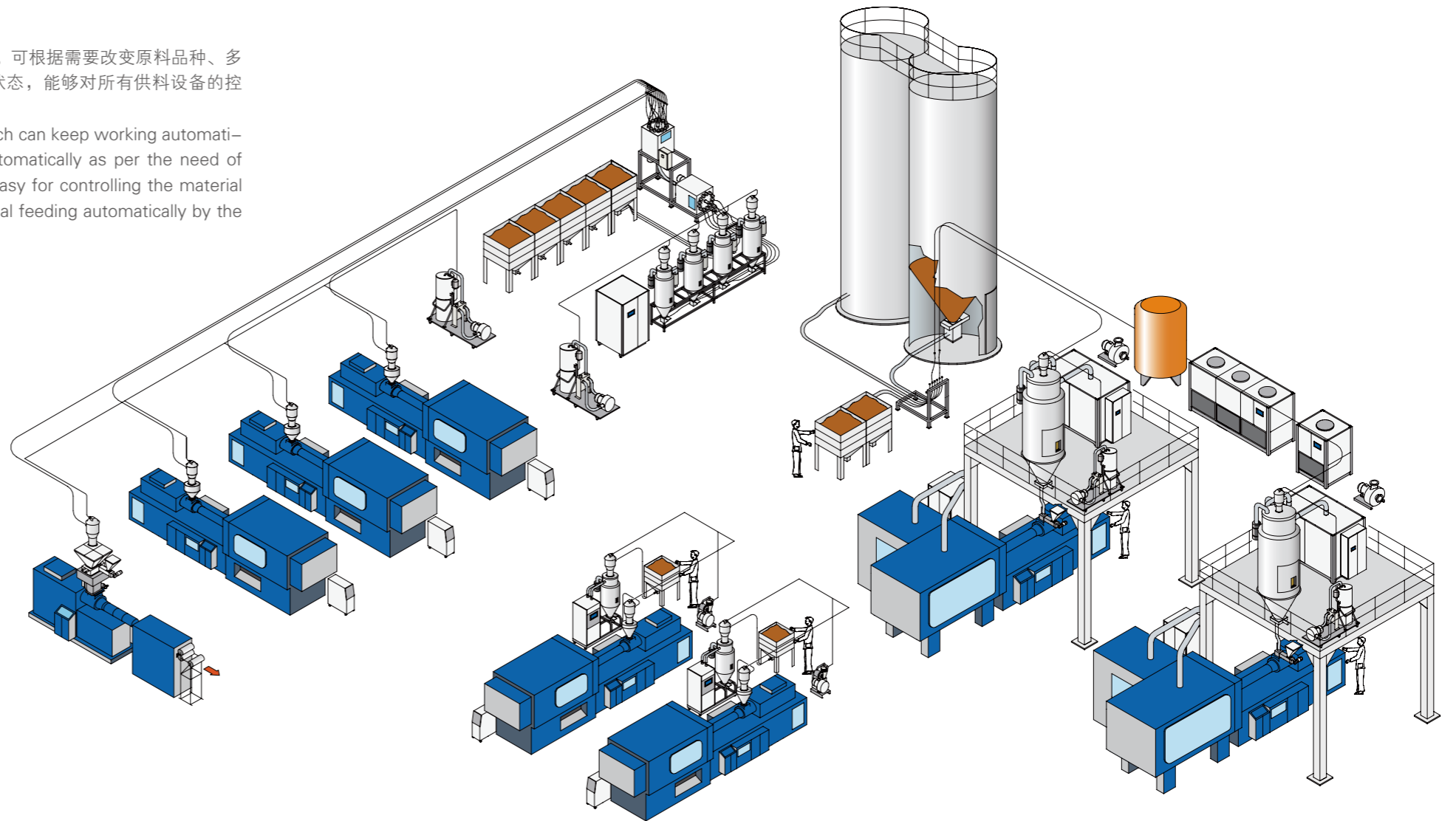

流程: 原料→储存→计量→干燥→输送→使用

Process: material→storage→metering→drying→feeding→use

特点: 高效、节能、个性化、现代化工厂形象

Features: efficient、energy saving、individuation、image of modern forming factory



计量
Metering



干燥
Drying



配管
Piping



中央气泵
Central air pump



输送
Conveying



脉冲集尘器
Pulse dust collector

EVA/PVC医用薄膜生产线

EVA/PVC Medical Film

PVC医用膜广泛应用于：医用PVC材料是一种血液相容性的高分子，在医学用途的高分子PVC材料的实际应用方面，有非常多的器件必须与血液相接触，比如：各种类型的体外循环系统、介入治疗系统等。应用的产品有：医用输液袋，废液袋，血液透析（视窗）袋、呼吸面罩等。

PVC medical film is widely used: medical PVC material is a blood-compatible polymer. In the practical application of polymer PVC material for medical purposes, many devices must be in contact with blood, such as: various Type of extracorporeal circulation system, interventional treatment system, etc. The products used are: medical infusion bags, waste liquid bags, hemodialysis (window) bags, breathing masks, etc.

EVA是一种新型的高分子材料，因其物理化学性能稳定，弹性好韧性高，易于加工，透光度高，耐腐蚀，无毒，无味，无污染等特点，目前已广泛应用于食品及医疗耗材领域（如营养液袋，输血袋等），已成为国际上普遍信赖和推崇的新一代医疗和食品包装材料。

EVA medical film is widely used: EVA is a new type of polymer material, because of its stable physical and chemical properties, good elasticity and toughness, easy processing, high light transmission, corrosion resistance, non-toxic, odorless, pollution-free, etc. At present, it has been widely used in the field of food and medical consumables (such as nutrient solution bags, blood transfusion bags, etc.), and has become a new generation of medical and food packaging materials that are generally trusted and respected internationally. The bag body made of EVA material is transparent, and the scale is clear, which is convenient for observing the position of the liquid surface.



PEEK/PPS/PPSU冷推棒材板材生产线

PEEK/PPS/PPSU Cold Push Bar and Sheet Production Line

PEEK中文名称为聚醚醚酮。主要运用在航天、医疗、制药和食品加工工业得到了非常普遍的应用，如卫星上的气体分析仪结构件、热交换器刮片；因其优越的耐摩擦性能，在摩擦应用领域成为理想材料，如辊筒轴承、滑动轴承、阀门座、密封圈、泵耐磨环等。The Chinese name for PEEK is called polyether ether ketone. It has been widely used in aerospace, medical, pharmaceutical and food processing industries, such as gas analyzer structural parts and heat exchangers on satellites. Due to its excellent friction resistance, it has become an ideal material in the field of friction application, such as roller bearing, sliding bearing, valve seat, sealing ring, pump wear ring, etc.

PPS塑料(聚苯硫醚)是一种综合性能优异的热塑性特种工程塑料。PPS的主要用途还是在电子电器领域，如制作变压器骨架，高频线圈骨架、插头、插座、接线架、接触器转鼓鼓片及各种精密零件等。

PPS plastic (polyphenylene sulfide) is a kind of thermoplastic special engineering plastic with excellent comprehensive performance. The main use of PPS is in the field of electronic appliances, such as making transformer skeletons, high-frequency coil bobbins, plugs, sockets, wiring frames, contactor drum drums and various precision parts.



主要技术参数 Main technical parameters

机型 Model	SJZ45/25
适用原料 Material	PEEK/PPS/POM
主机转速 Main engine rate of revolution	10-49r/min
主电机功率 Main motor power	11KW
最大挤出量 Capacity (Max.)	20KG/H

备注：以上规格参数如有变更，恕不另行通知。Note: The specifications are subject to change without prior notice.



PE加碳黑铜塑复合生产线

PE Carbon Black Copper-plastic Composite Pproduction Line

复合型导电高分子是在本身不具备导电性的高分子材料中掺混入大量导电物质，如炭黑、金属粉、箔等，通过分散，表面铜皮复合等方法构成的复合材料。

Composite conductive polymer is a composite material made by mixing a large number of conductive materials, such as carbon black, metal powder, foil, etc., into the polymer material which is not conductive itself, and the surface laminated with copper sheet.

与传统导电材料相比较,复合型导电高分子材料具有许多独特的性能。

Compared with traditional conductive materials, composite conductive polymer has many unique properties.



PS\PC电子载带挤出机

PS\PC Electronic Narrow Band Extruder

PS\PC电子载带属于包装类产品，主要用于IC、电阻、电感、电容、连接器、保险丝、开关等电子元器件的包装。这种产品目前都是PS与PC进行三层复合挤出成型。

PS\PC narrow band is a kind of packaging products, mainly for the IC, resistance, inductance, capacitance, connectors, fuses, switches and other electronic components of the packaging. This product is currently PS and PC for three layers of composite extrusion.

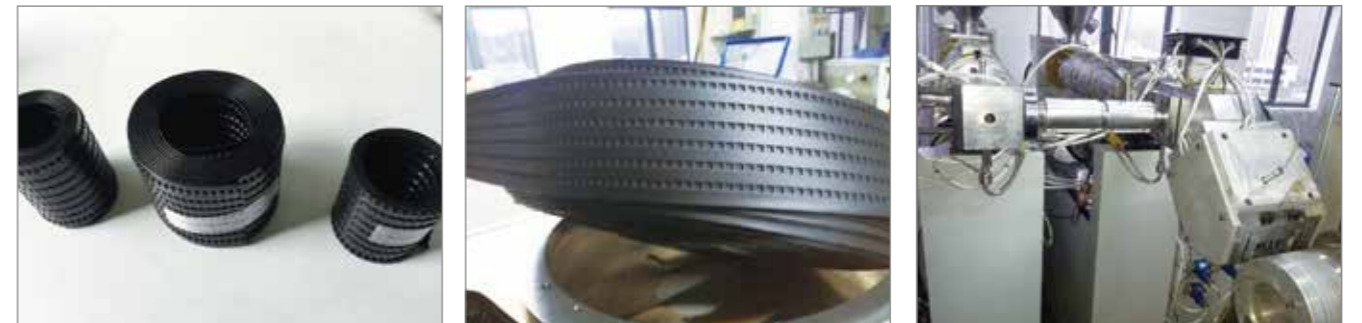

主要技术参数 Main technical parameters

挤出机型号	螺杆直径	长径比	电机功率	螺杆转速	挤出量	设备中心高
Model	mm	L/D	KW	rpm	kg/h	mm
JWS45	45	28:1	11	10-75	10-15	1000
JWS35	35	28:1	7.5	10-75	8-12	1000

备注：以上规格参数如有变更，恕不另行通知。Note: The specifications are subject to change without prior notice.



片材模头系列

Sheet Die Series

JW-P-K1

Fast opening die series, the upper die lip with fine-tuning push-pull type, the flexible lower die lip can adjusting product thickness on-line without stop, the Max adjusting range up to 5 mm, Equip with 45 ° blocking bar, it is suitable for produce PC, PS, PP, PE, PLA, single-layer or multi-layer plate .

快速开口系列模头，上模唇推拉式微调，柔性下模唇可实现不停机在线快速调整制品厚度规格，调节范围最大达 5mm，带 45 度节流棒调节装置，适用生产 PC、PS、PP、PE、PLA 等单层或多层片板。



JW-P-A1

With coat-hanger channel, micro-adjustable upper die lip, the die is perfect for single-layer or multi-layer PET(APET, PET)PC, PS, PP, PLA plate with the width ≤ 2100 mm, and the thickness between 0.14-2mm.

标准衣架式流道设计，上模唇可微调，适用生产 PET(APET、PETG) PC、PS、PP、PLA 等，单层或多层片板，宽度 ≤ 2100 mm，厚度 0.14-2mm。



JW-P-AT1

Auto-adjusting die, the upper die lip is adjusted by the auto-control system which divided into manual-control unit and auto control unit; the first can control the accuracy in 1mm and the latter 300um. Fits for PC, PS, PP, PE, PLA single-layer or multi-layer sheet or film with different width.

自动调节模头，上模唇含自动控制单元，分为手动调节和自动调节两部分，手动调节范围在 1mm。自动调节范围在 300um。适用 PC、PS、PP、PE、PLA 等不同宽度的单层、多层片材或薄膜。

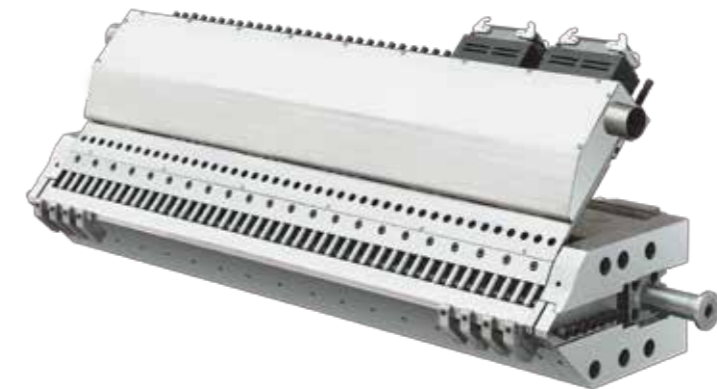

JW-P-D1

With multi-manifold design, the die can combine the materials inside to ensure the accuracy of the film. The die adopts micro-adjustable upper die lip, fixed lower lip and 45 ° blocking bar, which is fit for PC, PS, PP, PE, PLA multi-layer co-extrusion sheet.

模内复合模头，通过多流道模内复合，可有效提高各层面的薄厚精度。上模唇可微调、下模唇固定及芯层 45 度节流棒调节装置，适用生产 PC、PS、PP、PE、PLA 等多层共挤片材。

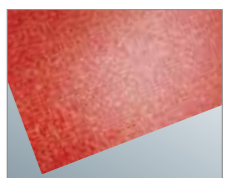

相关公司产品链接 Linkage Of Relating Auxiliary Equipment



自动换网器和液压站
Hydraulic Screen Changer



失重式喂料装置
Dosing System



在线测厚仪
On-line Continuous Measurements



冷水机
Water Chiller Unit



挤出机
Extruder



各类镜面辊筒
All Kinds of Mirror Rollers



模具和分配器
T-die And Feedback



计量泵
Metering Pump



破碎机
Crusher

